

Wind Turbine Sale

5/6kw Osprey with Pitch controlled with more power than a Bergy 10kw



I . Introduction of 5kw pitch controlled wind turbine

5kw pitch controlled wind turbine, newly developed by , is a patented product and pioneer in domestic. The self-developed centrifugal pitch controlled mechanism of Wind turbine adjusts blade pitch following wind rotor rotating speed, and keep wind turbine at rated rotating speed. The wind turbine has a stable output power and safe running and is maintenance free. Wind rotor never goes to over speed even encounter to variable wind speed and strong gale.

Low wind speed start up, pitch regulation, safe system

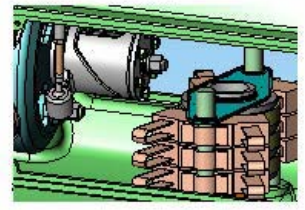
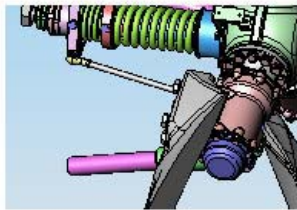
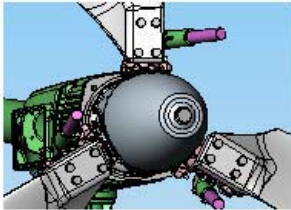
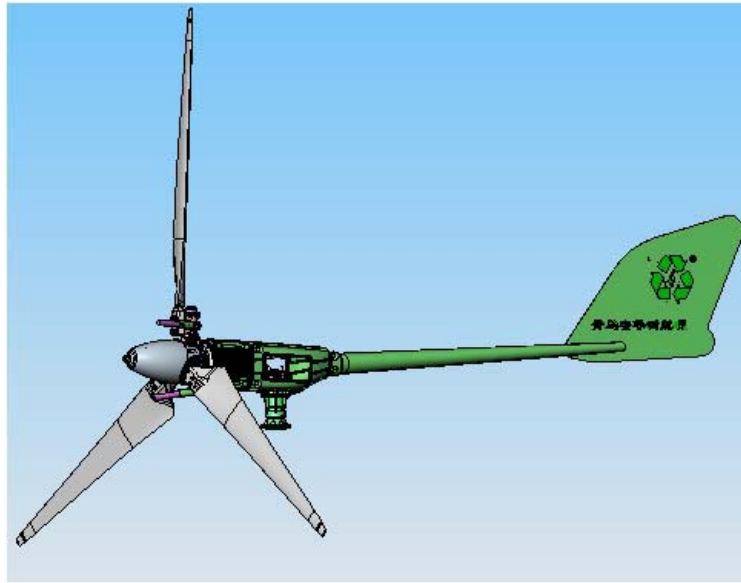

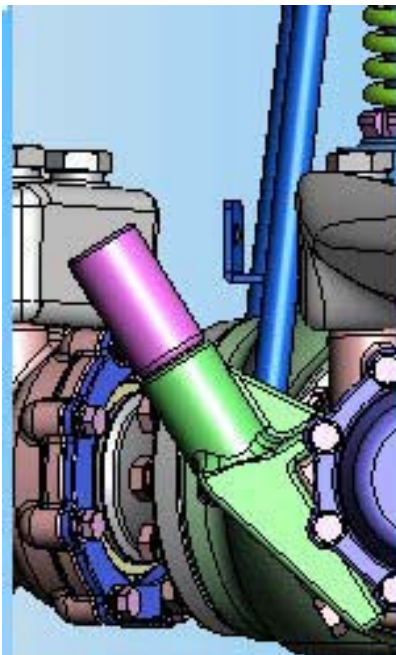

Centrifugal pole to adjust blade pitch

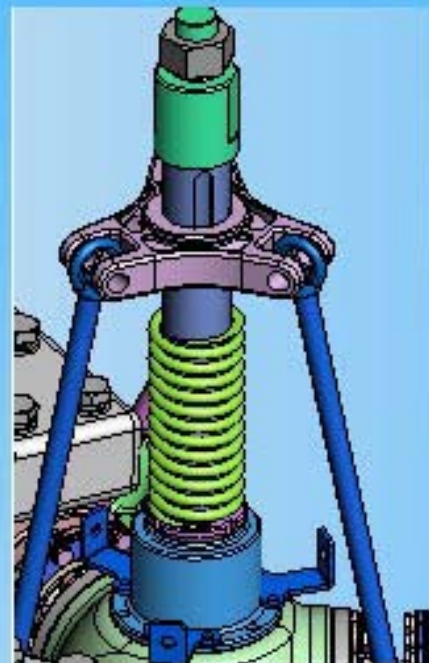

Spring restore

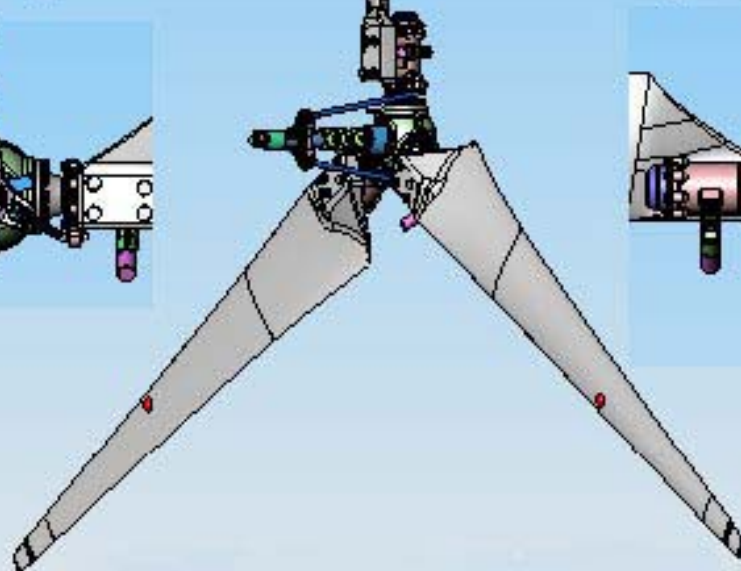
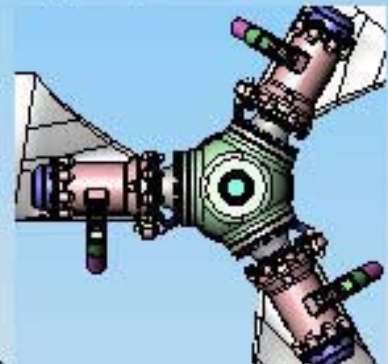
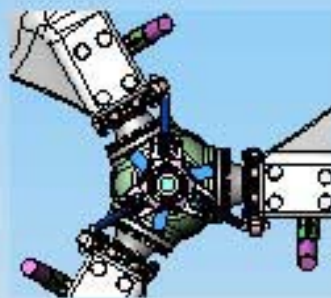

5kw pitch controlled wind turbine rotor structure

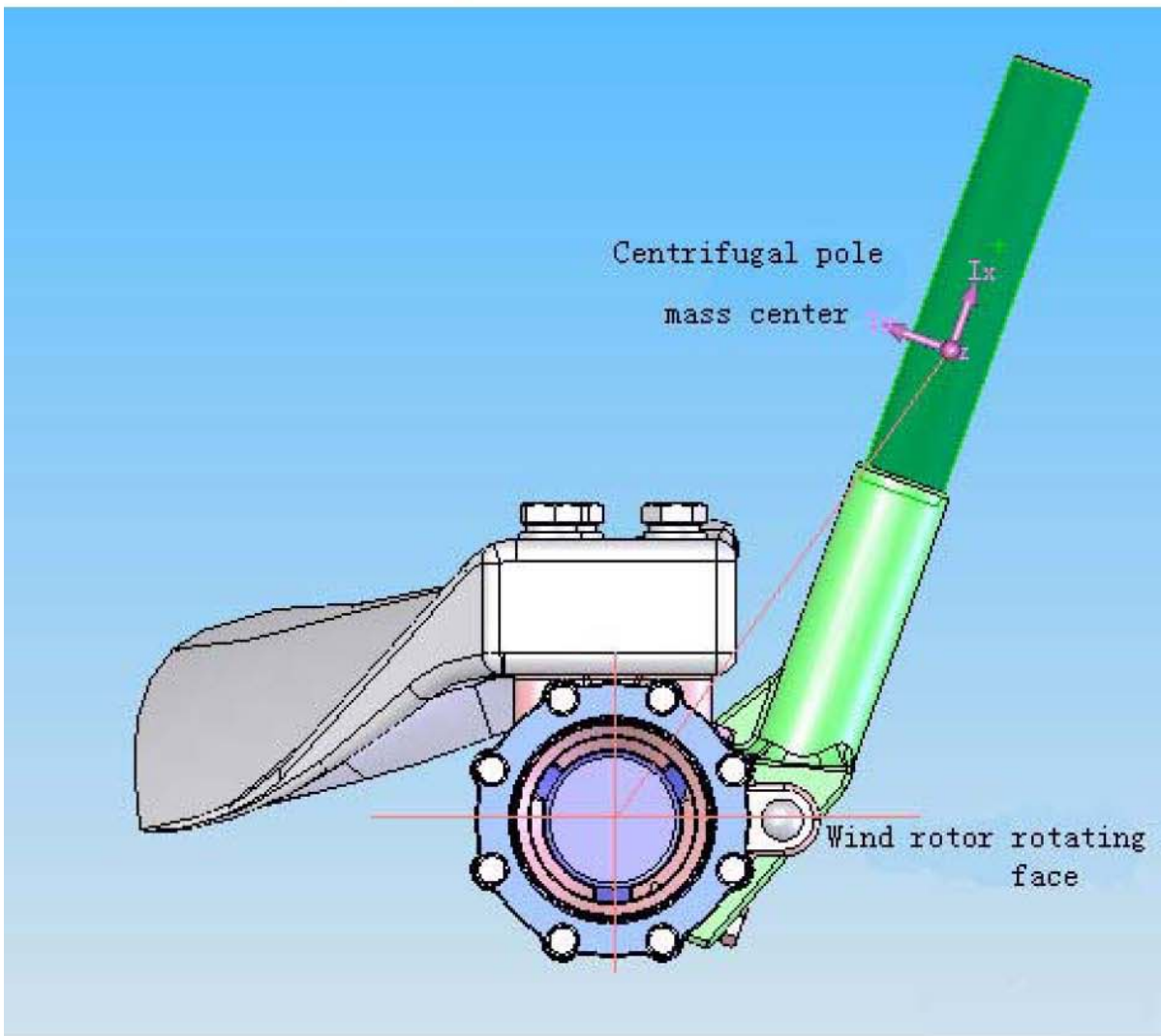
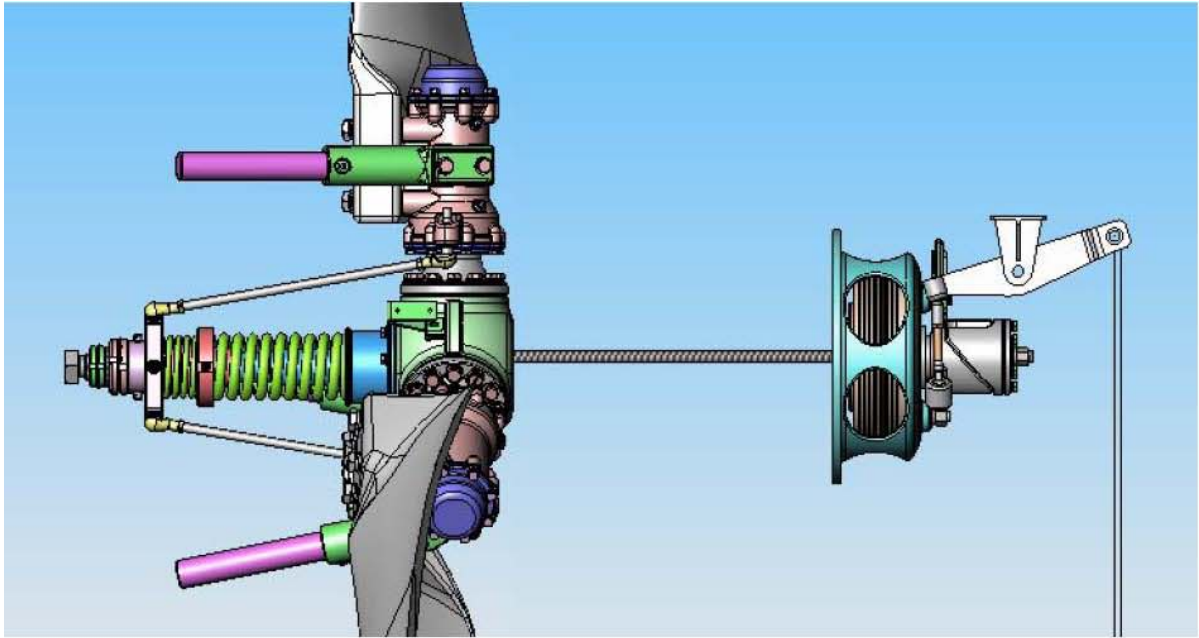

II . Characteristics:

1. 1. Optimum aerodynamic shape design: high efficiency, low noise.
2. 2. Centrifugal pitch controlled mechanism: 2m/s low wind speed startup; 3-12m/s wind speed, following wind rotor rotate speed to adjust blade angle at optimum TSR, run in high efficiency; over rated wind speed, wind rotor never goes to over speed and has stable control; 3-25m/s wind speed, wind turbine can run smoothly.
3. 3. Direct drive permanent magnet generator, low startup resistance moment, constant running ability of over loading 1.5 times, maintenance free for more than 30000 hour.
4. 4. Safety control: has aerodynamic brake, electric magnet brake, mechanical brake and manual stop mechanism.
5. 5. Sealed slip ring, no cable twist;
6. 6. Streamline design.
7. 7. Long acting anticorrosive treats, no corrosion in 15years.

III 、 Pitch controlled element

Rotating speed change of wind rotor drives the centrifugal pitch control mechanism to adjust blade pitch; wind pressure on wind rotor will reduce, and then wind turbine rotating speed slow down. Close loop control, reliable regulation. Pitch control mechanism is sensitive, reliable, and can be used in variable environments.

Wind turbine start up: keep a big blade pitch, start up with 2m/s wind speed;
Wind turbine start to run: reduce blade pitch step by step, better for speedup;
4-12m/s wind speed: regulate the optimum blade pitch to keep the max output power of wind turbine;
Encountering to strong wind: adjust blade pitch into negative angle to keep rotating speed within limits;
Manual stop: operate manual winch to adjust blade pitch into negative angle, blade will lose it aerodynamics, start mechanical brake to stop wind turbine.

Osprey

V .Technical parameter :

Rotor Diameter (m)	5.2	Working Voltage (V)	DC120V/DC240V AC240
Material and number of the blade	Reinforced fibber glass*3	Battery voltage (V) / Capacity (Ah)	120V/200Ah 240V/100Ah
Rated power / max power (w)	5k/6k	Speed regulation method	Pitch controlled + yawing + electromagnet brake
Rated wind speed (m/s)	11	Stop method	Brake by hand drag
Rated rotating speed (r/min)	300	Generator style	Three phase, permanent magnet
Startup wind speed (m/s)	2	AA Tower height/weight (m/kg)	8/150
Working wind speed (m/s)	3-25	Weight (excluding tower)	400
Survived wind speed (m/s)	60	AAA Tower height / weight (m/kg)	8/450

USA Solar & Wind Inc.

Compare before you spend.

1 877 300 6007 usasolar@comcast.net

Test tower with SMA Germany Windy Boy 6000 and at 8m tower height

**Output Power
(P) watts**

6.7

24.64

mph

Bergey EXCEL - S compared to VP5 Osprey

2.24 mph = 1 m/s wind speed

15.68 mph = 7m/s Osprey VP5= 1400w

15.68 mph = 7m/s Bergey EXCEL - S= 1000w

14.0 mph = 6.25 m/s Osprey VP5= 1000w

14.0 mph = 6.25 m/s Bergey EXCEL - S = 800w

20.16 mph =9.00 m/s Osprey VP5=3000w

20.16 mph =9.00 m/s Bergey EXCEL - S =2200w

24.64 mph = 11 m/s Osprey VP5= 6100w

24.64 mph = 11 m/s Bergey EXCEL - S = 4000w

All Data for this reference was compiled from each

chart supplied by OEM from each wind turbine company. March 19, 2009

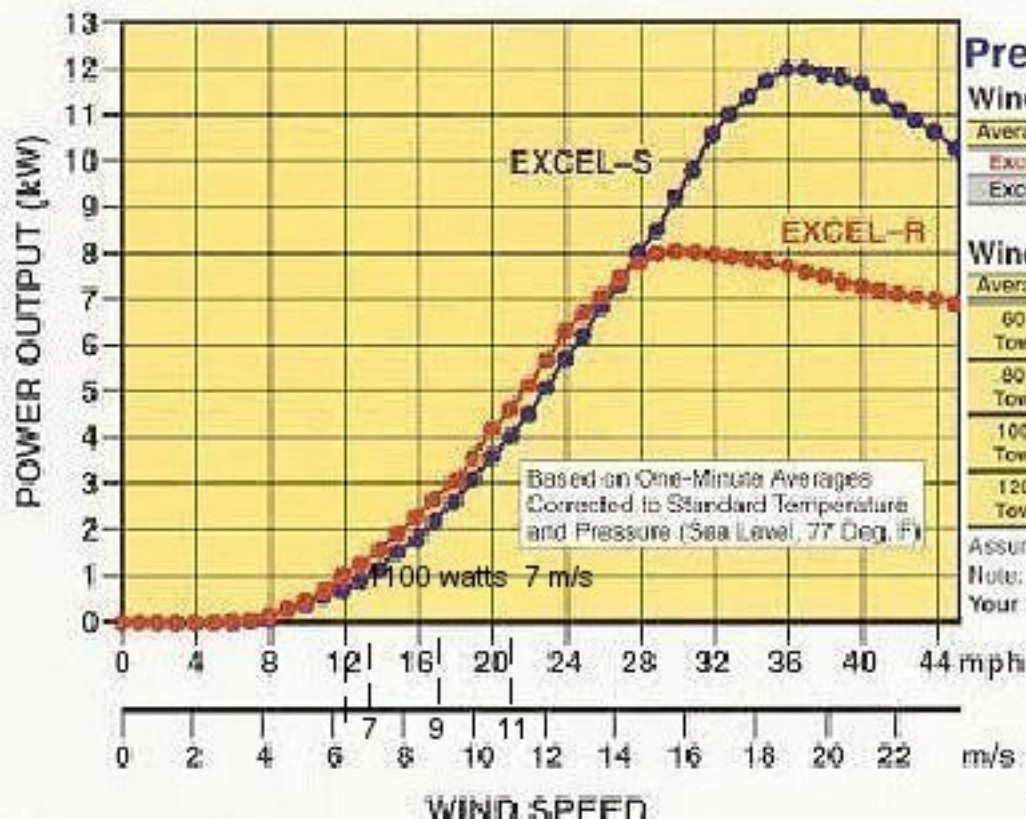
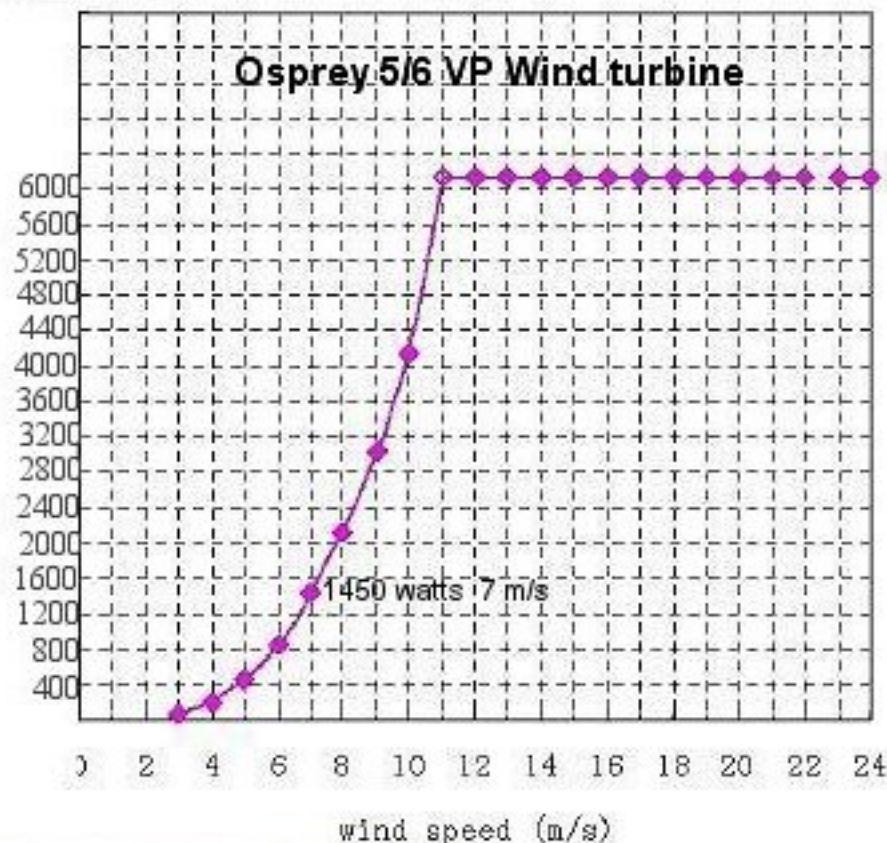

Predicted Monthly Energy Production

Wind Speeds Taken at Top of Tower

Average Wind Speed	8 mph	9 mph	10 mph	11 mph	12 mph	13 mph	14 mph
Excel-S (AC kWh)	240	370	520	700	900	1,130	1,370
Excel-R (DC kWh)	340	500	680	880	1,090	1,320	1,550

Wind Speeds Taken at 10 meters (per standard wind resource maps)

Average Wind Speed	8 mph	9 mph	10 mph	11 mph	12 mph	13 mph	14 mph
60 ft. Tower	Excel-S: 330 Excel-R: 440	Excel-S: 480 Excel-R: 620	Excel-S: 670 Excel-R: 830	Excel-S: 870 Excel-R: 1,050	Excel-S: 1,110 Excel-R: 1,280	Excel-S: 1,350 Excel-R: 1,510	Excel-S: 1,610 Excel-R: 1,740
80 ft. Tower	Excel-S: 430 Excel-R: 560	Excel-S: 620 Excel-R: 780	Excel-S: 840 Excel-R: 1,030	Excel-S: 1,100 Excel-R: 1,290	Excel-S: 1,370 Excel-R: 1,550	Excel-S: 1,670 Excel-R: 1,820	Excel-S: 1,980 Excel-R: 2,050
100 ft. Tower	Excel-S: 490 Excel-R: 630	Excel-S: 700 Excel-R: 870	Excel-S: 950 Excel-R: 1,140	Excel-S: 1,220 Excel-R: 1,410	Excel-S: 1,510 Excel-R: 1,680	Excel-S: 1,820 Excel-R: 1,950	Excel-S: 2,130 Excel-R: 2,200
120 ft. Tower	Excel-S: 550 Excel-R: 700	Excel-S: 780 Excel-R: 960	Excel-S: 1,050 Excel-R: 1,240	Excel-S: 1,340 Excel-R: 1,530	Excel-S: 1,650 Excel-R: 1,800	Excel-S: 1,970 Excel-R: 2,070	Excel-S: 2,290 Excel-R: 2,320

Assumptions: Inland Site, Rayleigh Distribution, Shear Exponent = 0.16, Altitude = 1,000 ft.

Note: Battery charge regulation (batteries full) will reduce actual Excel-R performance.

Your Performance May Vary.

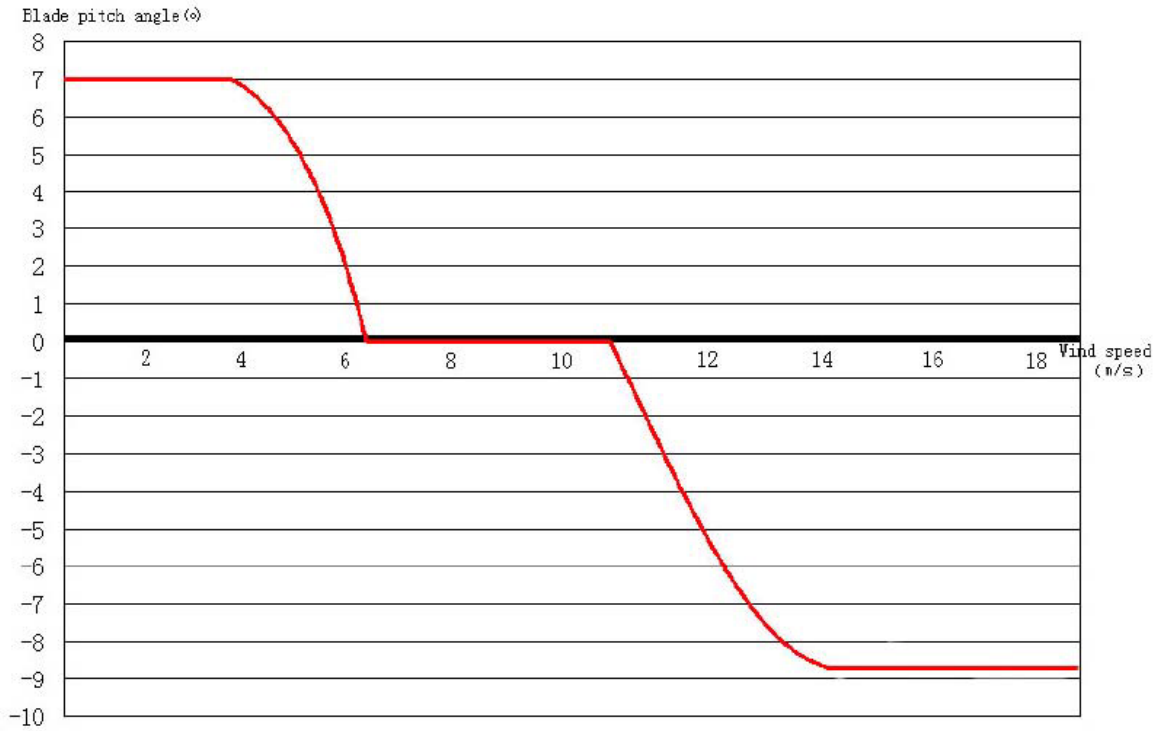

5kW wind speed - wind turbine blade pitch angle curve



新随风至
Innovation in Wind Power
动世界

1151

所有展品均由
中国科技馆提供

本展品为风能发电原理的实物模型，展示了风能的利用。展品由清华大学工程热物理研究所设计，由北京航空航天大学制造。

All-Flow Pitch controlled wind turbine introduction
Low wind speed start up pitch regulation, auto control

All-Flow pitch controlled wind turbine, newly developed by Qinghai Aosheng
pitched and power in Denmark. The self-developed horizontal pitch control

所有展品均由
中国科技馆提供



21世纪是信息时代，也是能源时代。随着科学技术的进步，人类对能源的需求日益增长。风能作为一种清洁、可再生的能源，越来越受到人们的重视。风能发电具有无污染、无噪音、运行成本低等优点，是未来能源发展的主要方向之一。我国风能资源丰富，开发利用潜力巨大。通过大力发展风能发电，不仅可以缓解能源短缺问题，还可以保护生态环境，实现可持续发展。